

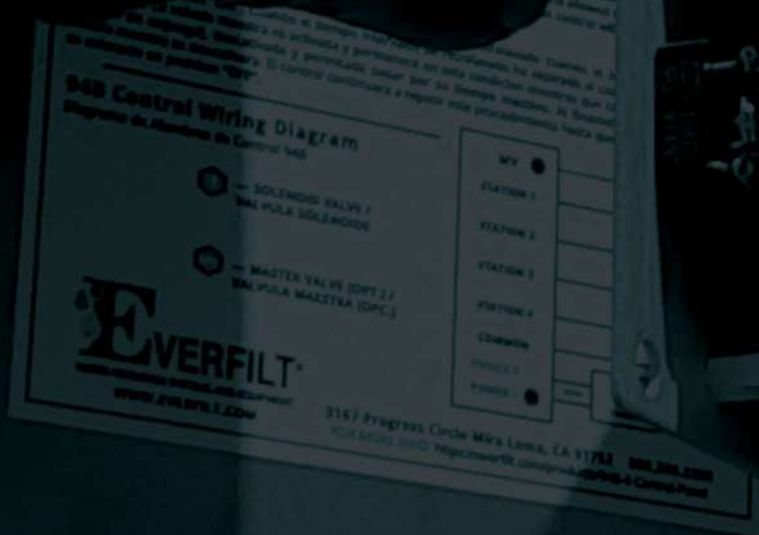

WATER FILTRATION SYSTEMS AND EQUIPMENT

**94B-12L**

BACKWASH CONTROL  
OWNER'S MANUAL



[WWW.EVERFILT.COM](http://WWW.EVERFILT.COM)

## 94B-12L Series — Automatic Backwash Controls

The 94B-12L Series is a solid-state filter backwash control, capable of operating one master valve, and up-to four backwash valves. The control will initiate a backwash cycle after reaching a pre-determined time or by receiving a signal from the pressure switch indicating a dirty filter condition. The control is equipped with an LCD display to monitor total number of backwash cycles, time until next backwash, and number cycles that have been initiated by the P.D. Switch.

### Operation

The control will begin timing of the backwash interval when the power switch is turned on. When the backwash interval time has expired, the control will initiate a backwash cycle. The master valve will energize and remain in this condition as each station is energized, de-energized, and allowed to pass through its dwell period. At the end of the backwash cycle, the master valve will de-energize. The control will continue to repeat this procedure until the power switch is turned off.



**NOTE:** If the P.D. on-off switch is in the "On" position, it will initiate a backwash cycle if the P.D. switch reaches its setting for approx. 15 seconds.

### Specifications

#### VOLTAGES:

Voltage Input (Transformer)	120 VAC	50-60 Hz
Voltage Input (Control Panel)	12 VDC / 12 VAC	50-60 Hz
Voltage Output	12 VCD	

#### LOADING:

Control Panel Dormant	25 MA
Sequencing	300 MA
Master Valve	1.0 AMP
Stations	2.0 AMP

#### TIMING:

Backwash Interval	0 Hrs. to 168 Hrs.
Flush Time	0 Sec. to 330 Min.
Dwell Time	0 Sec. to 90 Min.
P.D. Delay	0 Sec. to 360 Sec.

#### CAPACITY:

Master Valve	1
Stations (Std. Solenoid Valve)	1-4

#### DIMENSIONS:

Enclosure	Height: 11.50" Weight: 10.5 Lbs. Width: 7.62" Depth: 4.62"
-----------	--

### Controls

**A. SEQUENCE LAMP** - The lamp flashes when unit is in operation and remains lit during backwash sequence.

**B. BACKWASH INTERVAL** - The amount of time between backwash cycles. The interval is determined by **adding** the settings of both knobs together. Range 0 Hrs. to 168 Hrs.

**C. TEST BUTTON** - Depressing the test button will initiate a rapid system check of control outputs to solenoid valves. The master valve lamp will become illuminated and remain lit, as each station light turns on and off. The master valve light will turn off after the last station light turns off. The test cycle will not reset the backwash interval timing.

**D. FLUSH TIME** - The amount of time each individual filter will flush. The time is determined by **adding** the settings of both knobs together. Range 0 Sec. to 330 Min.

**E. DWELL TIME** - The amount of time between each individual tank backwash. The time is determined by **adding** the settings of both knobs together. Range 0 Sec. to 90 Min.

**F. POWER SWITCH** - Disconnects power to control panel.

**G. MANUAL START** - Depressing the manual start button will initiate a complete backwash cycle.

**H. P.D. ON-OFF SWITCH** - Disconnects pressure differential switch circuit from control.

**I. CIRCUIT BREAKER** - Provides overload protection for control.

**J. STATION LAMPS** - Indicates which station is in flush mode by remaining lit. The lamp will then flash to indicate the dwell condition.

**K. MASTER VALVE LAMP** - Indicates master valve is energized by remaining lit during the backwash cycle.

**L. LCD DISPLAY** - The LCD display will provide the operator with the following info: *See next page.*



## Controls (Cont'd)

1. **COMPLETED BACKWASH CYCLE** - Displays the total number of completed backwash cycles completed by the control.
2. **NEXT BACKWASH CYCLE** - Displays the time in hours and minutes until the next backwash cycle will start.
3. **P.D. TRIP QTY.** - Displays the number of times the pressure differential switch has initiated a backwash cycle.
4. **MODE** - Indicates either filtration mode, or backwash mode.

**NOTE:** All the above values will be stored in the controllers memory, when the power switch is turned off.

**M. RESET BUTTON** - Pushing the reset button will reset the completed backwash cycle and P.D. Trip Qty. values.

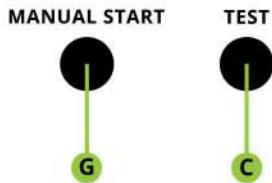
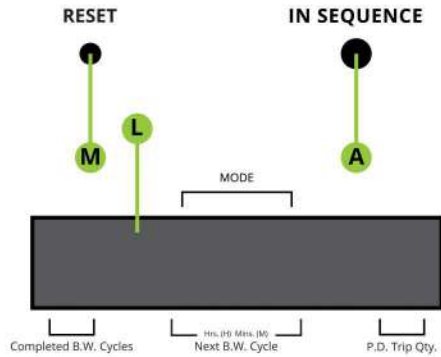

### 1. BACKWASH INTERVAL

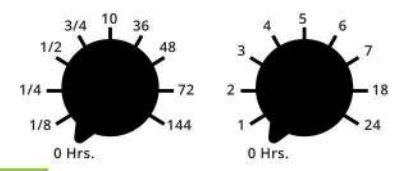

### 2. FLUSH TIME

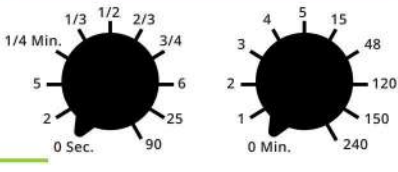

### 3. DWELL TIME

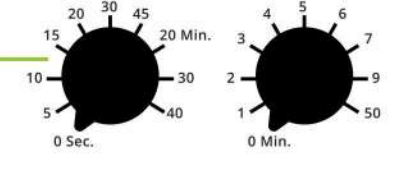

**MODEL 94B-12L BACKWASH CONTROL**  
12VAC/12VDC INPUT  
12 - STATION

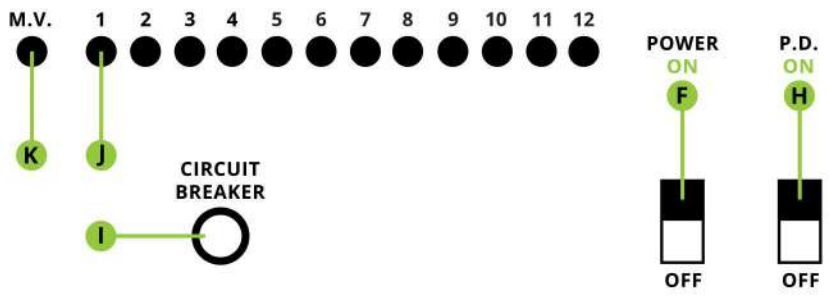

## 94B-12L Series — Automatic Backwash Controls

### Installation

A. Thread control mounting plate into 2" coupling on inlet manifold and attach backwash control per Figure 1.

Figure 1.  
**CONTROL MOUNTING**

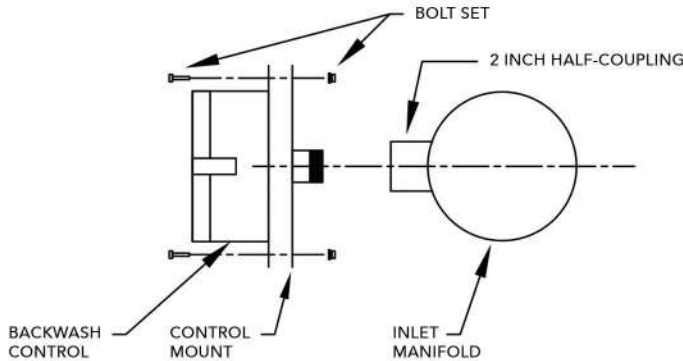

### Installation

B. Assemble hydraulic pick up assembly, connect solenoid valves to actuators, and make all hydraulic line connections per Figure 2.

Figure 2.  
**AUTOMATION HYDRAULICS**

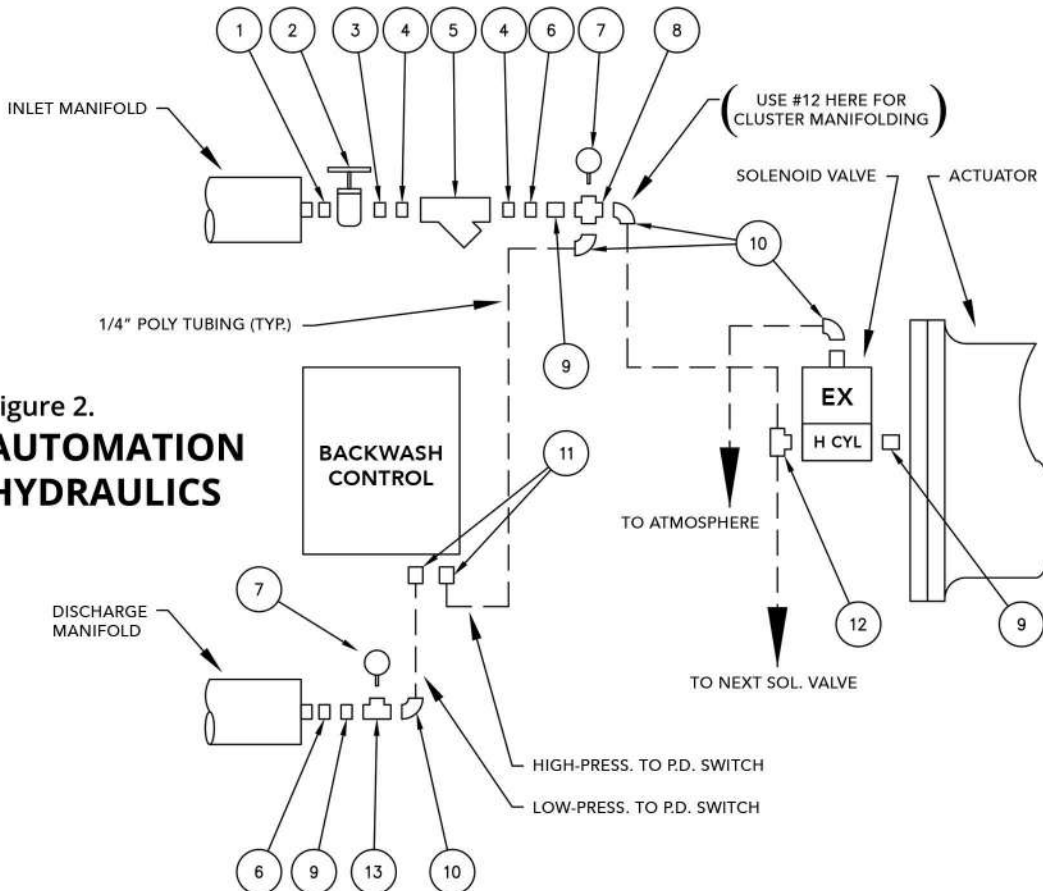

- 1 1/2" CLOSE NIPPLE
- 2 1/2" GATE VALVE
- 3 1/2" CLOSE NIPPLE
- 4 3/4" x 1/2" RED BUSHING
- 5 1/2" Y STRAINER
- 6 1/2" x 1/4" RED BUSHING
- 7 PRESSURE GAUGE OPT or OPT
- 8 1/4" TEE
- 9 1/4" CLOSE NIPPLE
- 10 P4ME4 POLY FITTING
- 11 P4FC2 POLY FITTING
- 12 P4MT4 POLY FITTING
- 13 1/4" TEE



## 94B-12L Series — Automatic Backwash Controls

### Installation

C. Route control wiring for solenoid valves per Figure 3.

NOTE: For older style three-wire latching solenoid valves, consult factory. Solenoid configurations may vary, depending on system type, and customer specifications.

#### ELBOW CONNECTION DETAIL

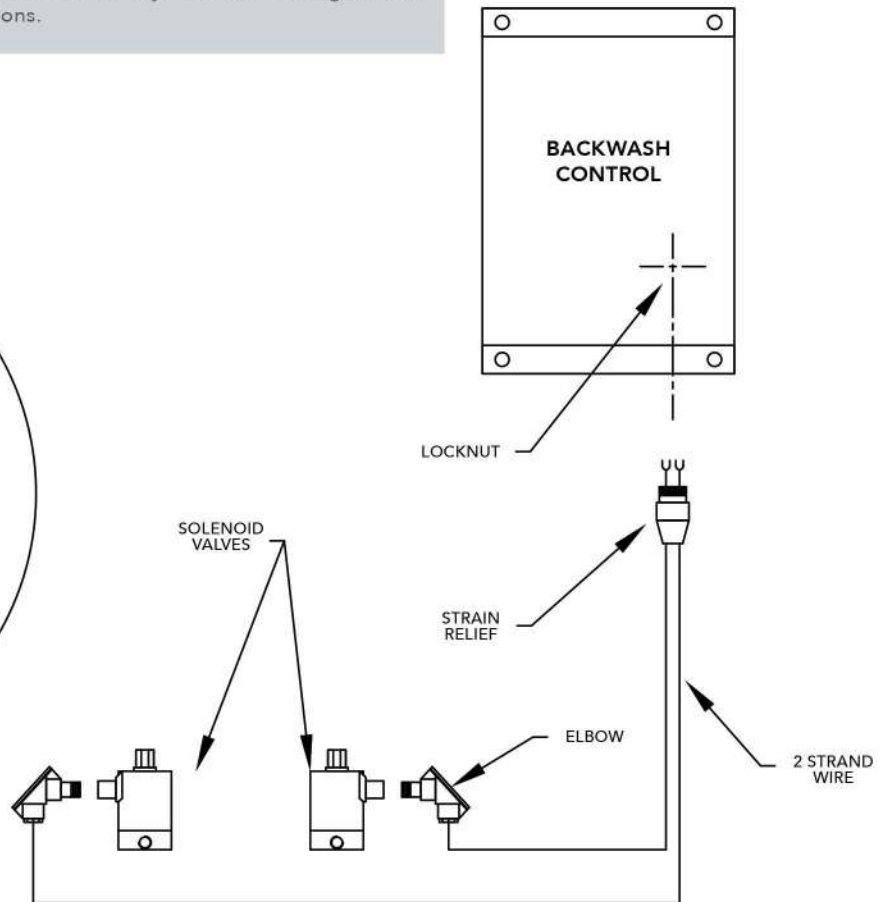
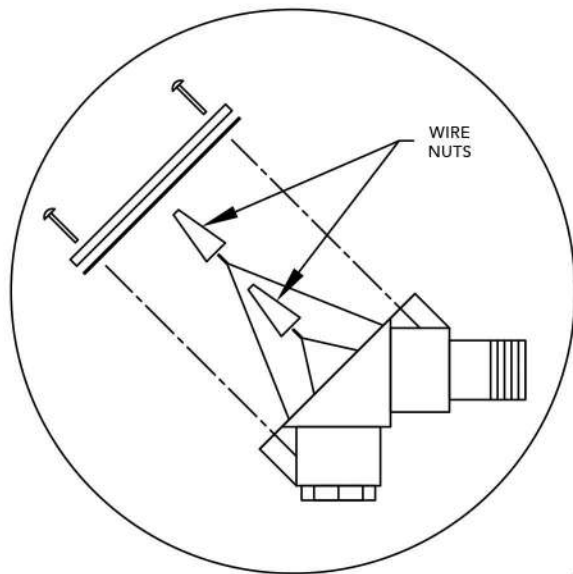
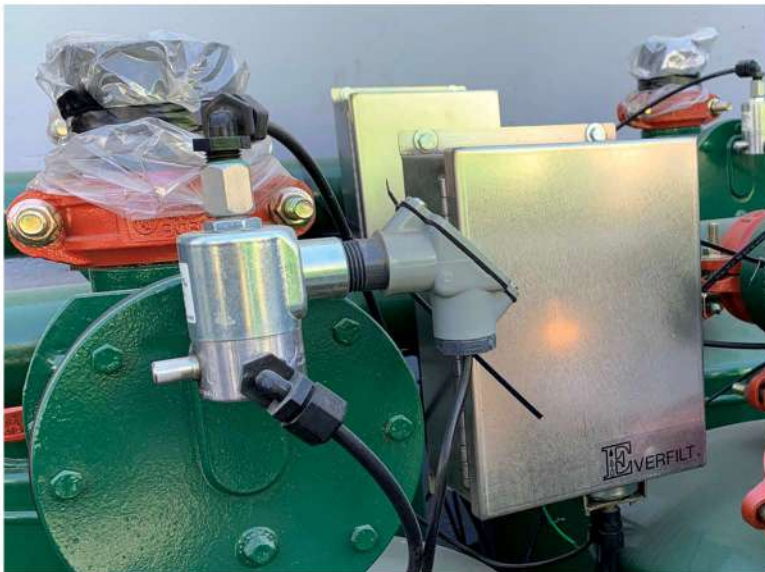

Figure 3.  
**CONTROL  
WIRE ROUTING**



AG TYPE SOLENOID INSTALL: ( SM, SSM, SK-SM, SK-SSM, HP-SM, HP-SSM )



INDUSTRIAL TYPE SOLENOID INSTALL: ( M, A, I )

## 94B-12L Series — Automatic Backwash Controls

### Wiring Diagram (Std. Operation)

D. Use Figure 4. to make all wiring connections for standard two-wire solenoid valves.

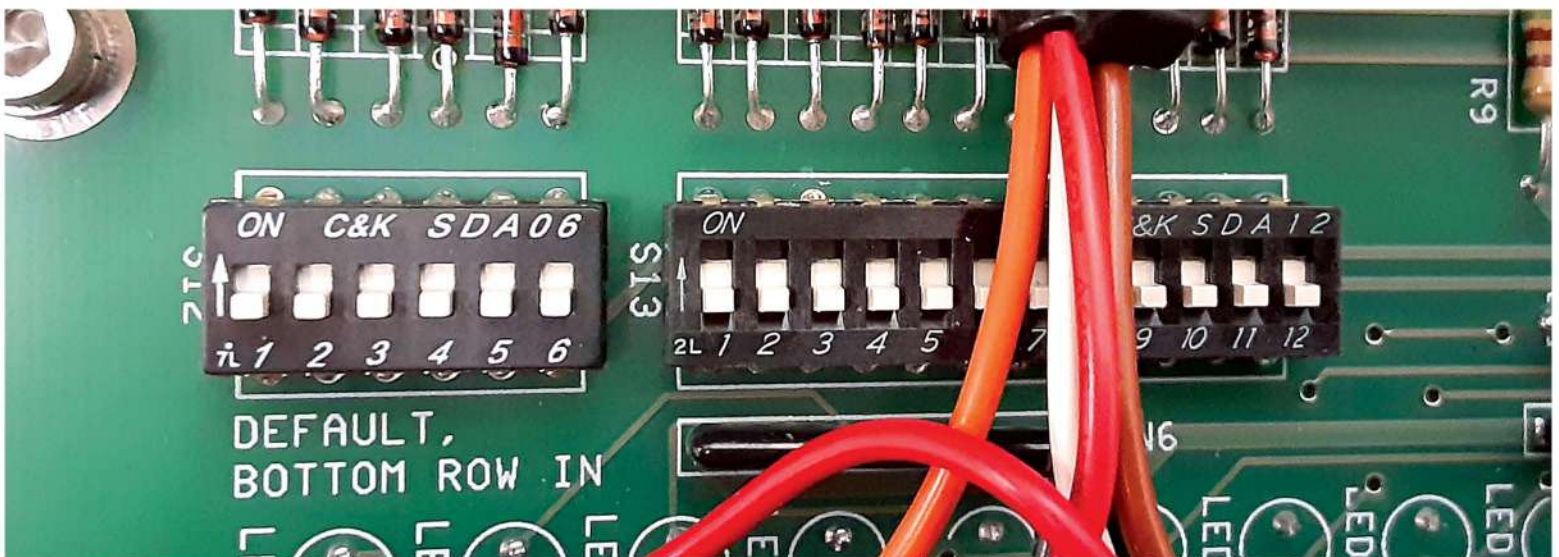
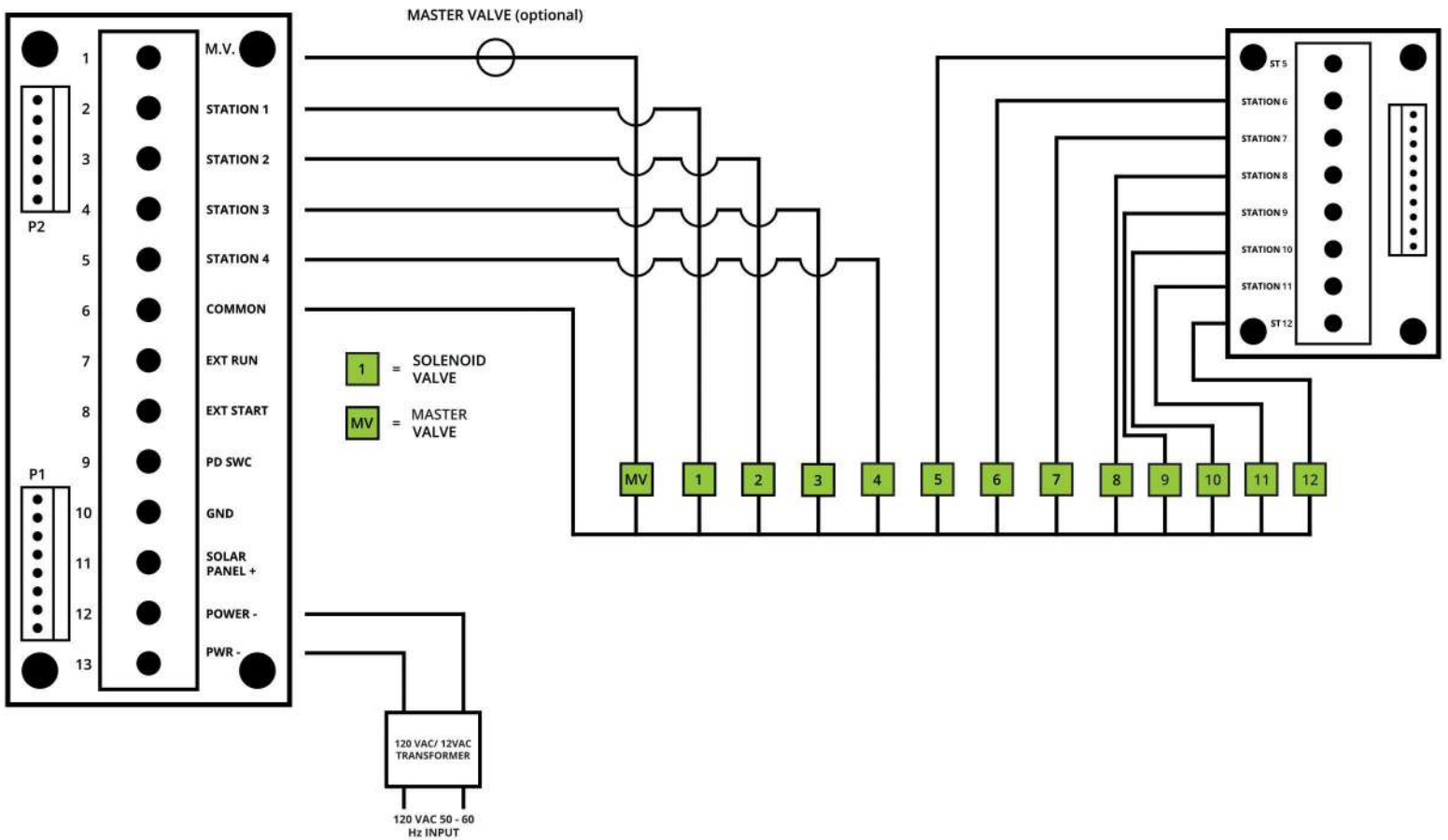



## 94B-12L Series — Automatic Backwash Controls

### Initial Start-Up

#### A. Two-Wire Solenoid Valves

For initial start-up, use the following backwash control settings:

	SCREEN FILTERS	MEDIA FILTERS
BACKWASH INTERVAL _____	1 hour	1 hour
FLUSH TIME _____	1 minute	2 minutes
DWELL TIME _____	10 seconds	10 seconds
P.D. SWITCH _____	6 PSI	6 PSI

#### B. Final Time Settings

After initial start-up, adjust time settings on backwash control to yield maximum filter performance for the existing water condition. After 50 minutes, observe the pressure readings on the inlet and discharge manifolds. If the pressure differential is approaching 6 PSI, **DO NOT** change the **BACKWASH INTERVAL**.

However, if the P.D. is substantially below 6 PSI, increase the Backwash Interval. As soon as the first backwash cycle is completed, observe the pressure differential. If the P.D. is greater than 3 PSI, **INCREASE** the **FLUSH TIME**.

Repeat this procedure for the first several backwash cycles until the **FLUSH TIME** is long enough to return the P.D. to 1 - 3 PSI after completion of backwash. This will indicate that the **FLUSH TIME** has been long enough to return the media to a clean bed condition.

These settings should be evaluated periodically and adjusted as water quality changes. Doing so will maintain maximum filter performance.



## 94B-12L Series — Automatic Backwash Controls

### Optional Settings

The **94B-12L Control** is shipped ready for most normal installations. However, certain situations will require fine tuning of the P.D. Delay, timer mode, and last station backwash settings. This is accomplished by locating the **DIP Switch** assembly on the back of the control panel ( see Figure 6. ) and making final adjustments.

Figure 6. **PC BOARD DIP SWITCH**

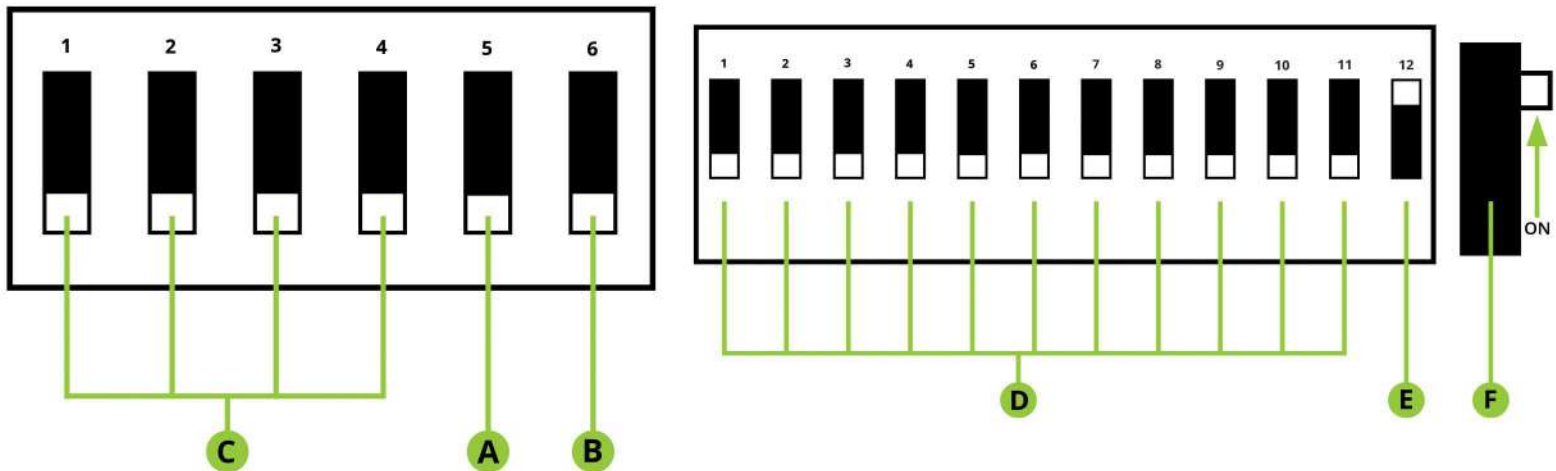

\*If you have a 12-tank system, then all DIP Switches must be down and #12 should be up. Depending on the number of tanks you have, that will dictate which switch must be up.

#### A. TIMER MODE SWITCH

This switch will change the starting time of the backwash interval count. The STD., "Off" position will allow backwash interval timing to reset at the beginning of the backwash cycle. The "One" position will allow backwash interval timing to restart at the end of the backwash cycle. The "Off" position will not allow the cycle to "creep" to different times of the day. ( Std. factory setting is "Off" ).

#### B. SLAVE SWITCH

This switch will disable the timing functions of the control and allow it to accept all commands for backwash interval, etc., from the designated master control. To allow the control to operate as a slave control, set the switch to the "On" position.

#### C. PRESSURE DIFFERENTIAL SWITCH DELAY

The P.D. Switch Delay can be adjusted from 0 seconds to 330 seconds, by using the combination of switch positions shown in Figure 7. ( Std. factory setting is 15 seconds ).

#### D. LAST STATION SWITCH

This switch will stop the backwash cycle at the last tank. The switches correspond to the stations as follows:

SWITCH #1 = TANK 1  
 SWITCH #2 = TANK 2  
 SWITCH #3 = TANK 3  
 SWITCH #4 = TANK 4

SWITCH #5 = TANK 5  
 SWITCH #6 = TANK 6  
 SWITCH #7 = TANK 7  
 SWITCH #8 = TANK 8

SWITCH #9 = TANK 9  
 SWITCH #10 = TANK 10  
 SWITCH #11 = TANK 11  
 SWITCH #12 = TANK 12



## C. PRESSURE DIFFERENTIAL SWITCH DELAY (Contd.)

Figure 7. Settings are: ( X = ON / O = OFF )

DIP SWITCH	POS 6	POS 7	POS 8	POS 9
15 Sec.	O	O	O	O
0	O	O	O	O
5	O	O	X	O
10	O	O	X	O
20	O	X	O	O
30	O	X	O	O
40	O	X	X	O
50	O	X	X	O
60	X	O	O	X
90	X	O	O	X
120	X	O	X	X
150	X	O	X	X
180	X	X	O	X
240	X	X	O	X
300	X	X	X	X
360	X	X	X	X

## DIP Switch

**E. MASTER ENABLE SWITCH** This switch will allow the control to become a master control and deliver all of its timing information to a slave control. The master control feature is useful for expanding systems.

**F. OFF POSITION OF DIP SWITCH** The DIP Switch is in the "Off" position when bottom edge is pushed in as shown.  
NOTE: The control is shipped in a default position, with all DIP Switched "Off".

## POLY FITTINGS

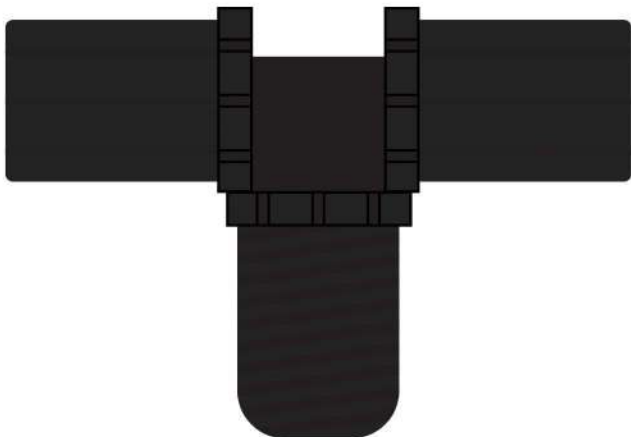

**1/4" OD TUBE X  
1/4" MPT TEE  
EVERFILT P/N 1104**

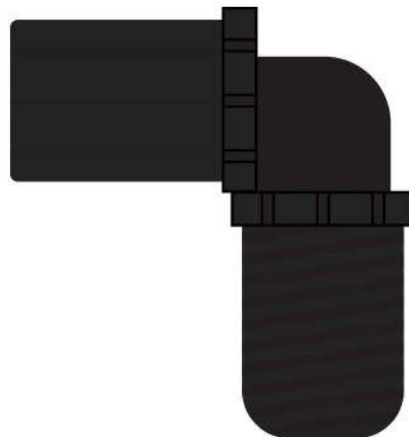

**1/4" OD TUBE X  
1/4" MPT ELBOW  
EVERFILT P/N 1105**

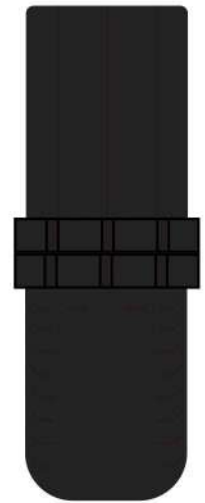

**1/4" OD TUBE X  
1/8" FPT COUPLING  
EVERFILT P/N 1155**